

Kämmer Series 051000

Tank Flush Valve



Series 051000

Description

This unique valve is typically used for On-Off bottom drain tank applications, where flushing or fluid transfer is necessary. The valve mounts flush to the tank with a plug extending into the tank and with the seat ring flush with the inner wall of the tank.

The valve's compact, lightweight design is ideal for in-line maintenance under the tank. It can be specified with either a 45° or 60° outlet angle. Other options include bellows seal, normalising fins, a special pocket-free body, steam jacketing or a plug that retracts into the body (as opposed to the standard design with an extending plug).

The tank flush valve can also be supplied as a control valve.

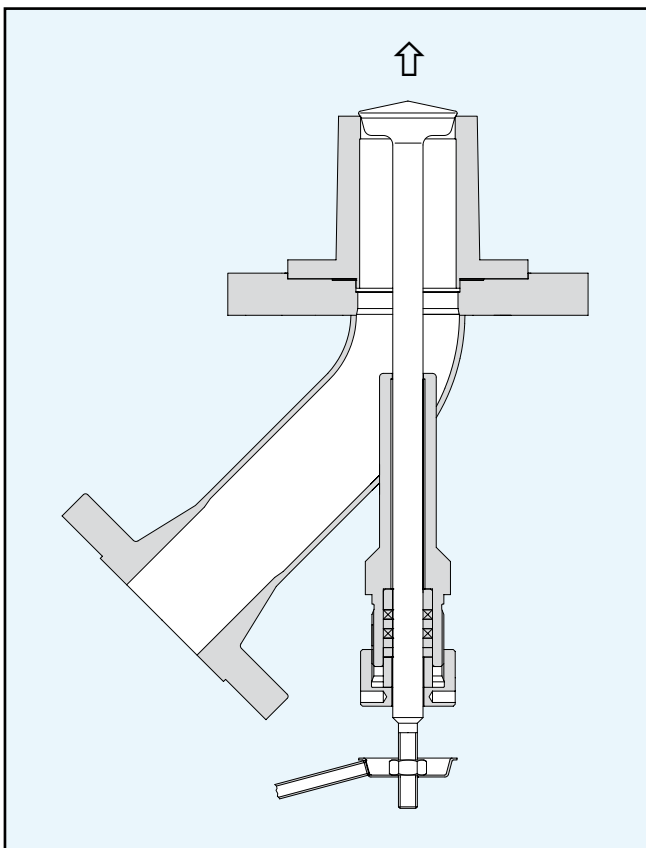

Standard valve with extending plug

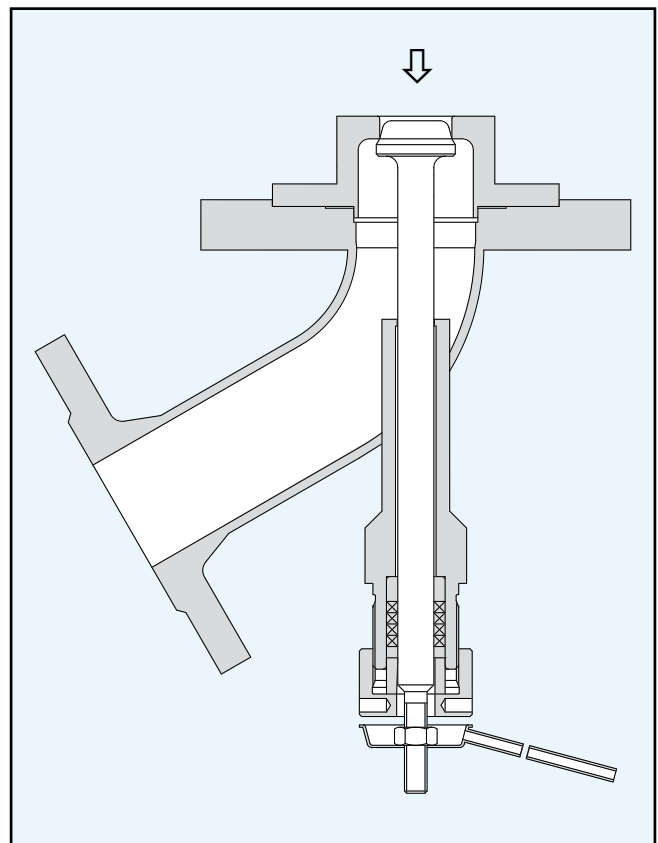

Special valve with retracting plug

Series 051000

Technical Data

Valve body style	Tank flush valve
Characteristics	On-Off, Linear, Equal%
Seat leakage	$\leq 0.01\%$ of K_{vs} -value, Class IV acc. to DIN IEC 534 - higher requirements on request
Body material	1.4571, other materials optional
Material for plug/seat ring	Same as body material
PTFE- soft seat (T=max 150°C)	Plug with PTFE insert for tighter seating
Packing	PTFE for temperatures up to 200 °C Grafoil for temperatures over 200 °C
Body gasket	PTFE for temperatures up to 200 °C, grafoil for temperatures over 200 °C
Designs	Valve with extending plug, valve with retracting plug, normalising fins, bellows seal
Sizes	The outlet size is either smaller or the same size as the inlet, see table on page 6
Connections	DIN-Flanges PN10 - 40 or ANSI Flanges Class 150 - 300
Outlet angle	45°, optional 60°
Seat ring height / seat diameter	30mm standard, other dimensions optional. Seat ring diameter made to customers request

Series 051000

Designs

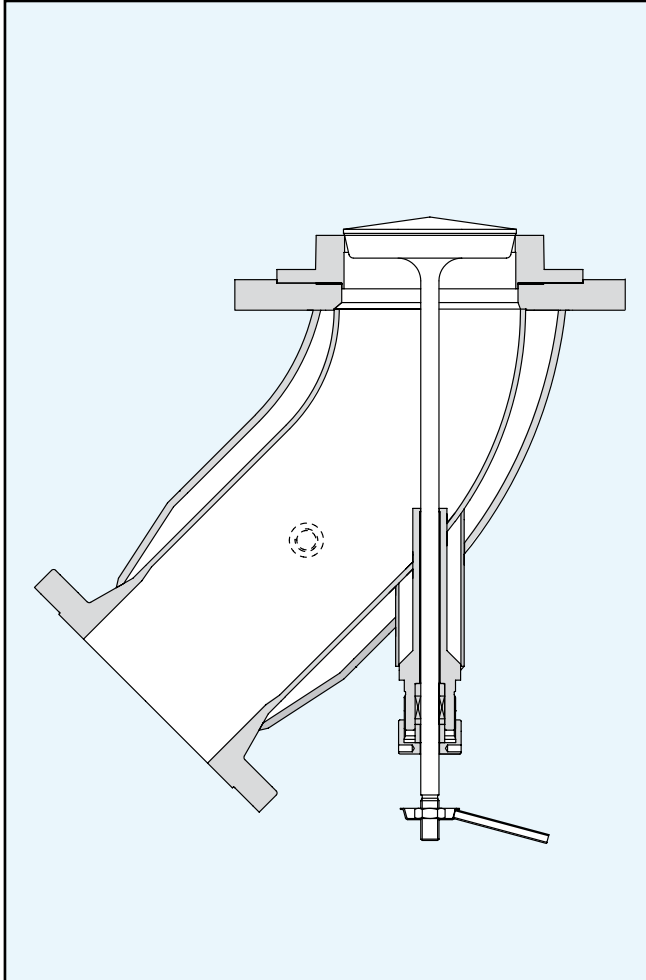

Special valve with steam jacket

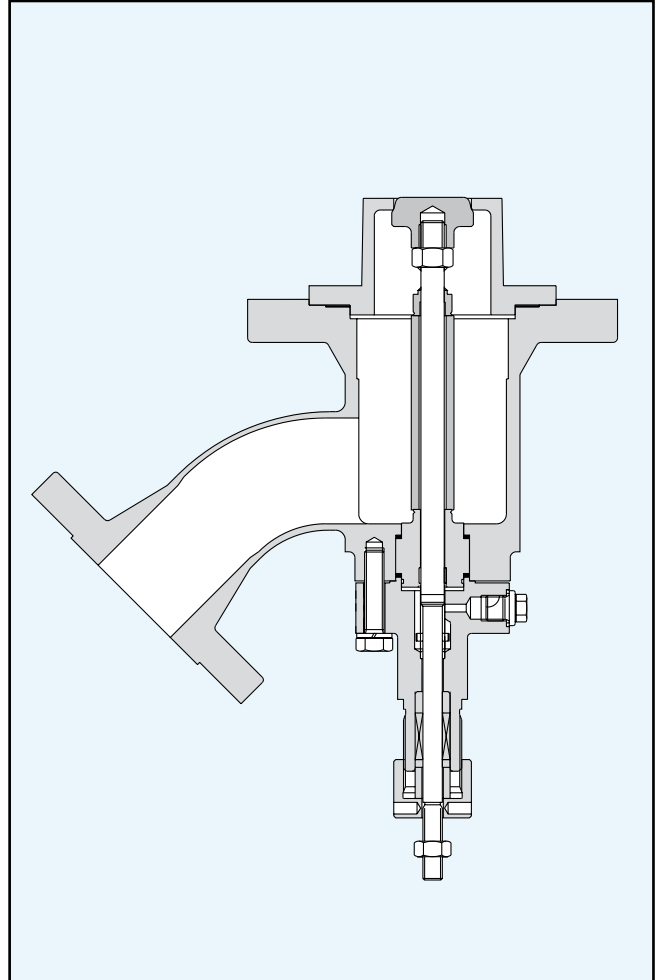

Special valve with bellows seal

Series 051000

Sizes

DIN PN 10-40	ANSI Class 150/300	Standard sizes	K _{vs} max. *	Seat dimensions mm
25 / 15 25 / 25 40 / 25 40 / 40	1" / ½" 1" / 1" 1½" / 1" 1½" / 1½"	X	4 4 16 25	16 16 25 32
50 / 40 50 / 50 65 / 50 80 / 50	2" / 1½" 2" / 2" 2½" / 2" 3" / 2"	X X X	40 40 63 63	40 40 50 50
65 / 65 80 / 65 80 / 80 100 / 80	2½" / 2½" 3" / 2½" 3" / 3" 4" / 3"	X X X	63 100 100 160	50 63 63 80
100 / 100 150 / 100 150 / 150 200 / 150	4" / 4" 6" / 4" 6" / 6" 8" / 6"	X X X	160 250 400 560	80 100 125 150

* K_{vs} values for standard extending plugs only. For special retracting plugs the K_{vs} value is reduced by around 50%.

Valve Code

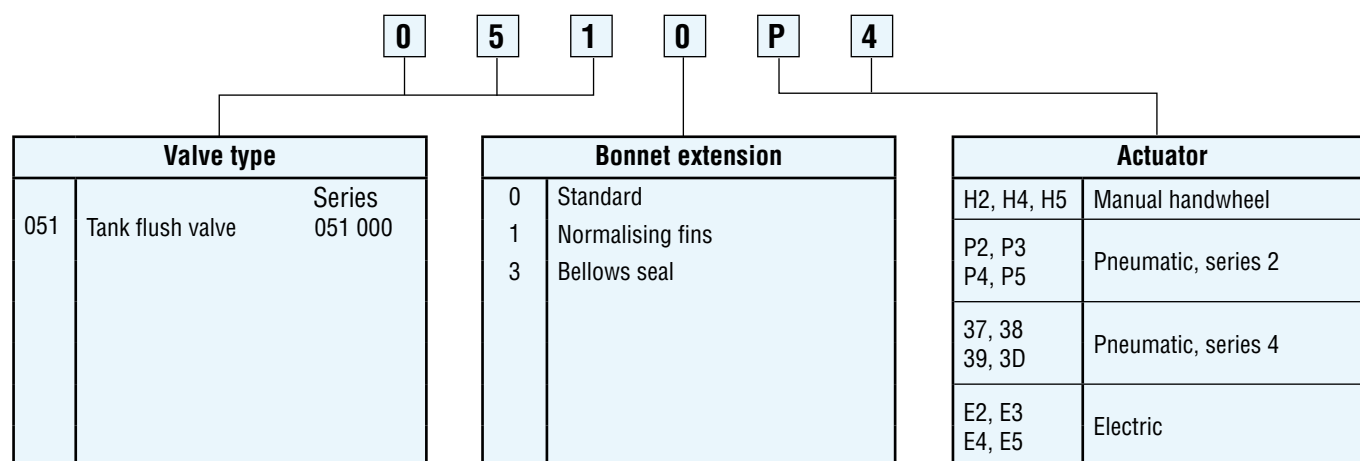

Series 051000

Dimensions (mm), Weight (kg)

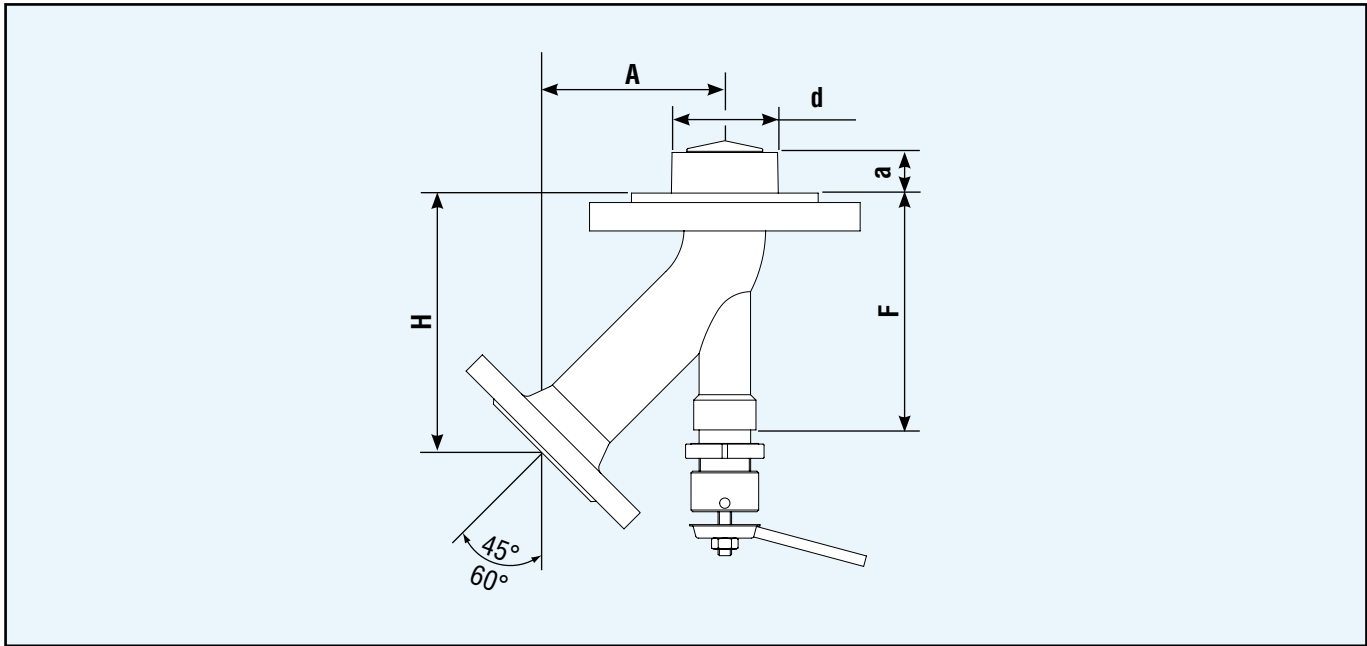

Valve DN	Dimensions*				Weights*			
	A	H		F	DIN-Flange		ANSI-Flange	
		45°	60°		PN 10-16	PN 25-40	Class 150	Class 300
25/15 – 1" / ½"	85	110	95	95	5.0	5.0	4.5	6.0
50/40 – 2" / 1 ½"	125	175	130	130	7.0	7.0	6.5	8.0
65/50 – 2 ½" / 2"	130	185	145	180	9.5	9.5	9.0	11.5
80/50 – 3" / 2"	130	190	155	180	9.5	9.5	9.0	11.5
80/65 – 3" / 2 ½"	135	200	160	200	11	13	13	16
100/80 – 4" / 3"	140	210	170	215	14	17	17	23
150/100 – 6" / 4"	200	295	235	240	19	25	23	37
200/150 – 8" / 6"	250	375	305	340	32	46	41	60

* All dimensions refer to the standard valve design. Dimensions for normalising fins and bellows seals on request.

Tolerance for dimensions A and H \pm 5mm.

Dimensions „a“ and „d“ are made to order.

Series 051000 Special Designs





Germany

Flowserve Essen GmbH
Flowserve Flow Control
Kämmer Ventile

Manderscheidtstrasse 19
45141 Essen

Germany

Tel.: +49 (0) 201 89 19 5

Fax.: +49 (0) 201 89 19 662

FCD KMEEBR5120-00 11.06

Your contact:

A large, empty dashed-line rectangular box intended for contact information.

All data subject to change without notice

©08.2000 Flowserve Corporation. Flowserve and Kämmer are trademarks of Flowserve Corporation